

Boston
Boston Acoustics

Your Sound Solution™

MicroSystem CD Owner's Manual



Thank you for choosing the Boston Acoustics® MicroSystem CD.

The MicroSystem CD is a state-of-the-art stereo radio/CD player and a versatile audio center that delivers the performance and versatility of precisely matched, separate components in one compact, easy-to-use unit.

Special Features

- You can preset as many as 12 FM and 12 AM stations for instant recall. See page 7.
- Play MP3, WMA, CD-R, and CD-RW as well as conventional CDs. To navigate your MP3 files, see page 9.
- Play an iPod® or other MP3 player through the convenient front-panel jack. See page 15.
- Play the sound from your TV and a CD changer or another audio device through the two rear-panel Auxiliary inputs. See page 13.
- Plug in headphones and automatically silence the internal speakers for private listening. See page 13.
- There are two independent alarms. You can choose to wake to music, beeper, or both. You can choose to fall asleep to one station and wake up to another or to a CD. See page 10.
- The built-in Sleep function lets you play the unit for up to 60 minutes before it shuts off automatically. See page 12.
- If there is a power failure or you unplug the MicroSystem CD to move it, the station presets, clock time, and all other settings are retained for up to 48 hours.
- The MicroSystem CD will wake you up even if there is a power failure! See page 3.
- When the system is in use, you can change the display to show either the time or status of the program to which you are listening. See page 12.
- The display dims automatically in the darkness. You can change the threshold if you wish. See page 13.
- Store the Remote Control in the flip-down door or use its magnet to “dock” it on a refrigerator or other metal surface. See page 3.
- Play the MicroSystem CD through another sound system or use it as a recording center. Or, you can connect a subwoofer for use in very large rooms and reconfigure the system’s operation. See page 14.
- Connect external FM and/or AM antennas for even better reception. See page 16.

Owner's Manual

Please save this owner's manual for future reference. If you should need an additional copy, it may be downloaded from the Boston Acoustics website: www.bostonacoustics.com/microsystemcd.

Unpacking the MicroSystem CD

Please save all the original packaging because it will provide the safest way to transport your unit.

Once unpacked, open the flip-down door and remove the Remote Control. Remove the paper tab on the Remote Control to activate the battery.

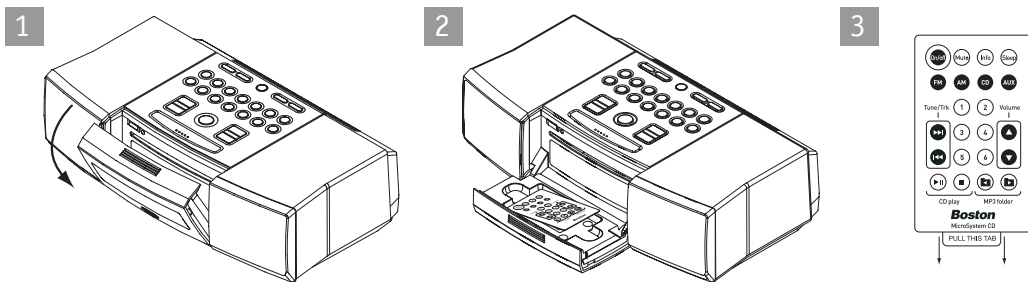

The backup alarm

Installing the supplied 9-volt battery in the compartment on the bottom of the MicroSystem CD will ensure that a beeper alarm will operate even if there is a power failure. If the battery needs replacement or if there is not a battery connected, you will see a “**battery low**” message whenever the MicroSystem CD is switched on.

Note: Please check with local laws and regulations regarding the proper disposal of batteries.

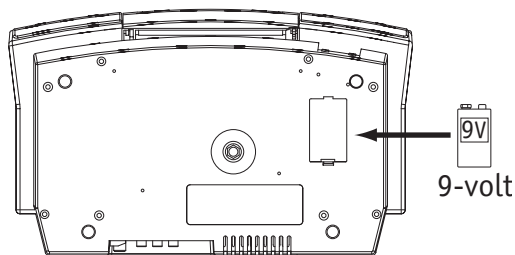

4 **Plugging in the power cord and Positioning the FM antenna**

The FM antenna comes attached.

1. Straighten out the antenna to its full length.
2. Orient the wire for the best reception. (The position for the best reception is guaranteed by Murphy's Law to be wherever it looks the worst, like draped over the front of the kitchen counter.)
3. You can use the included self-adhesive antenna clips to secure the FM antenna wire to a surface.

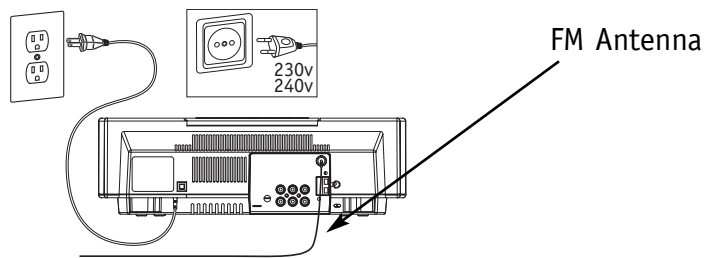

The Remote Control

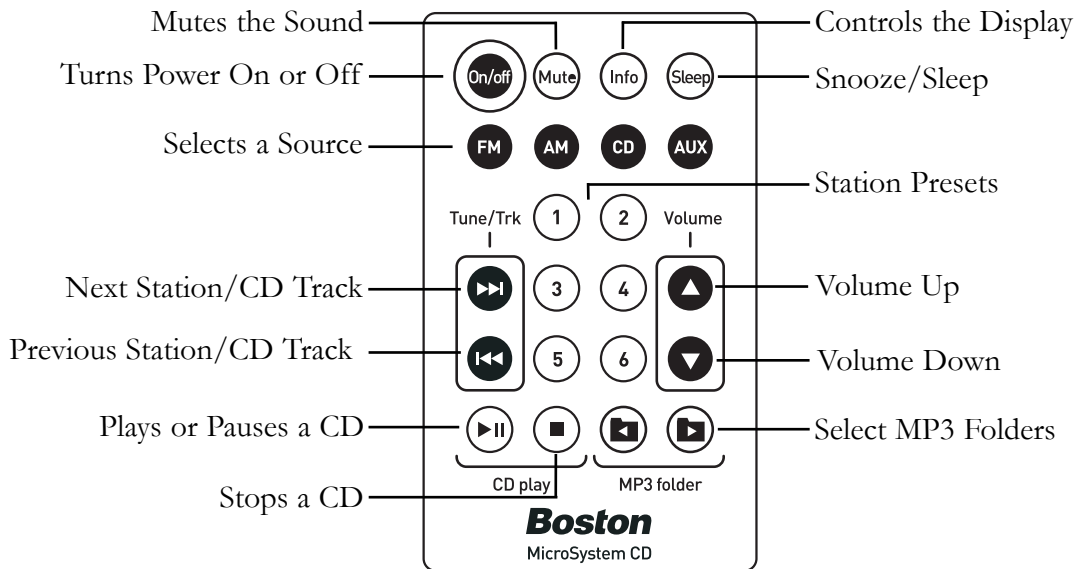

The Control Panel

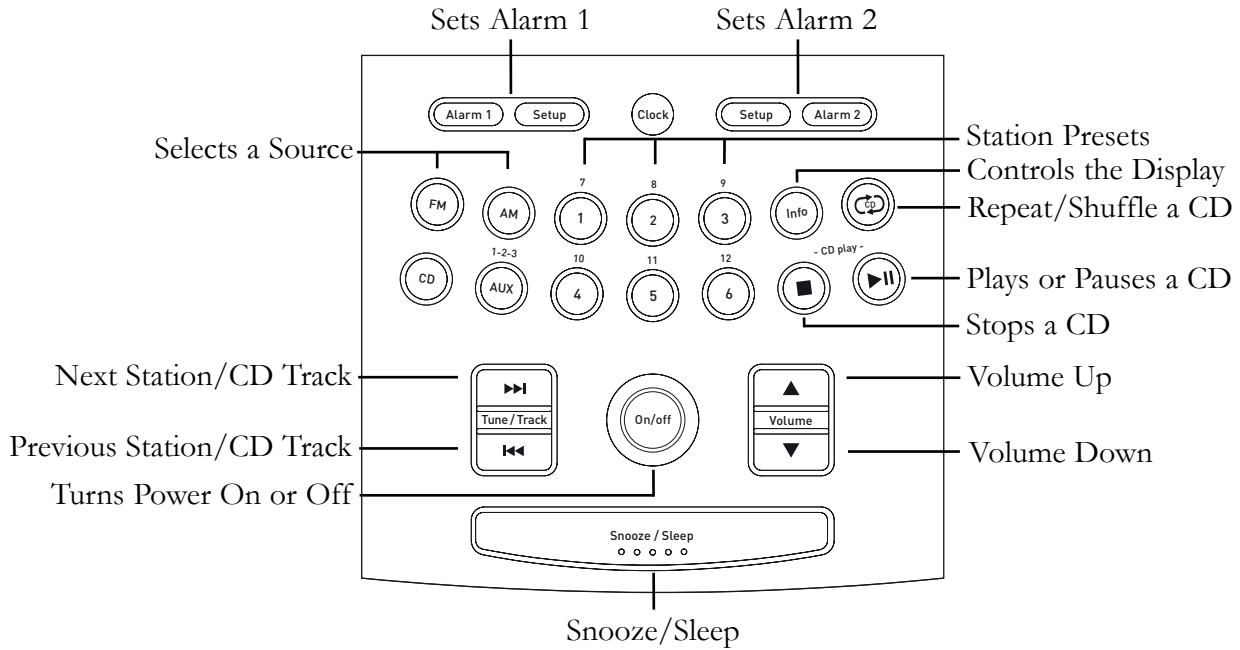

The Basics

Setting the clock

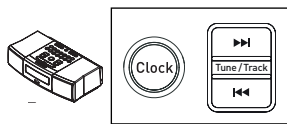

Press the **Clock** button for one second until the displayed time begins flashing. While it is flashing, use the **Tune/Track** arrow buttons to set the clock time. When you are finished, the display will stop flashing after a few seconds.

Note: If there is a power outage or you unplug the MicroSystem CD, the clock will continue to run and all other settings will remain in memory for up to 48 hours.

Turning on the system

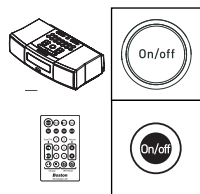

Press the **On/off** button on the MicroSystem CD or on the Remote Control to turn on the unit. The MicroSystem CD can also be turned on by any of the following: pressing a preset station button; pressing **AM**, **FM**, **CD**, or **AUX**; or inserting a CD.

6 The Basics (continued)

Turning off the system

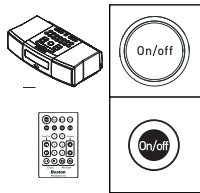

Press the **On/off** button to turn off the system.

Adjusting the volume

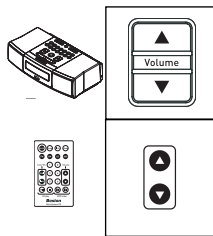

Press the **Volume** arrow buttons on the MicroSystem CD or on the Remote Control to adjust the volume. When the MicroSystem CD is turned on, the volume will return to the previous setting unless it was very loud, in which case it will go to 60.

Muting the system

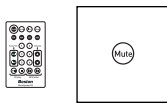

Pressing the **Mute** button on the Remote Control will mute all sound. The sound will remain muted until the **Mute** button or a **Volume** arrow button is pressed.

The Display

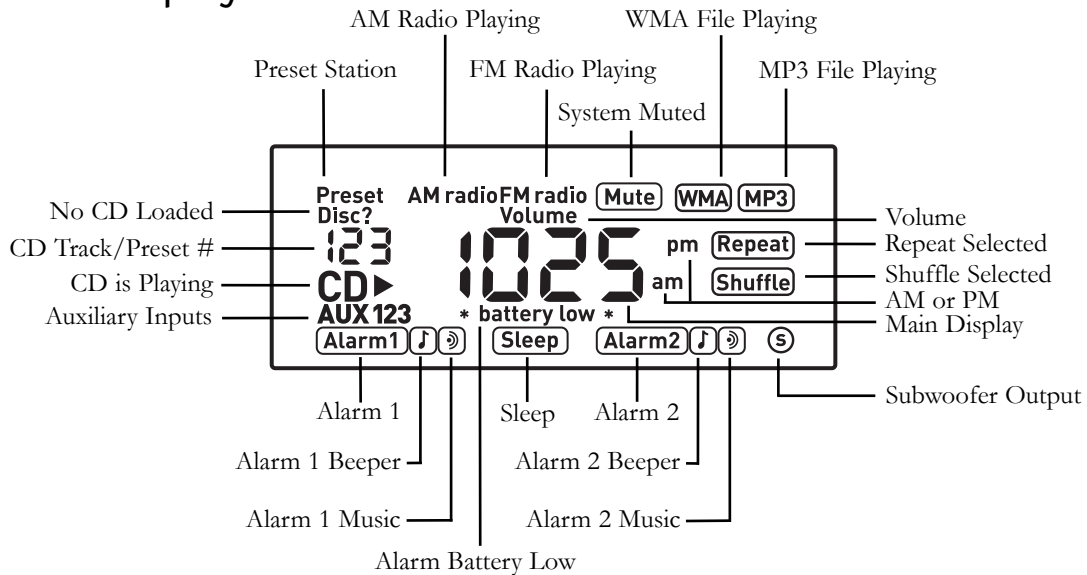

Tuning to an FM or AM station

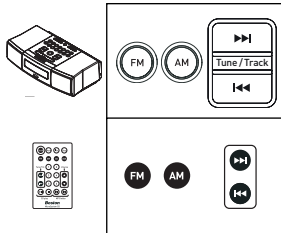

Press the **FM** or **AM** button to select the desired band.

- Press the **Tune/Track** arrow button once to automatically seek the next clear station.
- Tap the **Tune/Track** arrow button repeatedly to tune one frequency at a time.
- Hold down the **Tune/Track** arrow button to tune rapidly.

About FM Reception

FM signals are like TV signals. One antenna orientation may be best for one station but not for another. The straight wire antenna supplied with your MicroSystem CD is conveniently small. It should be extended to its full length, placed as far away from the power cord as possible, and oriented for best reception. If reception is weak, try changing the position of the wire antenna. Be sure not to run it along the power cord, as this will substantially decrease the signal reception.

If reception is still weak, you can improve it by connecting an external antenna. Your authorized Boston dealer or Boston's Technical Support Department can suggest solutions. In addition, many Cable TV systems provide an FM feed that can be connected to the MicroSystem CD via its standard Type-F antenna connection. See page 16.

About AM Reception

MicroSystem CD has a built-in AM antenna. If reception is weak, try rotating the system clockwise and counterclockwise to improve signal strength. If this does not solve the problem, you can improve AM reception by connecting an external AM antenna. See page 17.

Storing FM and AM stations

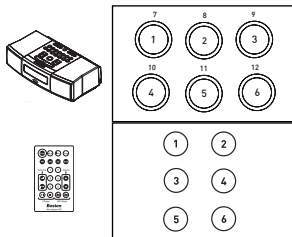

You can store any station by holding down any one of the numbered Preset buttons for 3 seconds until the MicroSystem CD beeps. The display will show the Preset number. Pressing its Preset button will recall the station and will turn on the MicroSystem CD if it is off. Each Preset button can store one station for AM and another for FM.

Storing a second set of presets

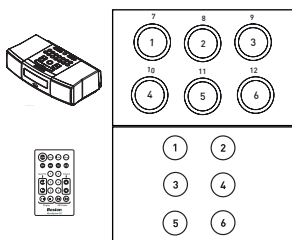

The MicroSystem CD can store a second group of Presets. To store Preset numbers 7 through 12, tune to the desired station, select the Preset button that is paired with the number printed above it, and quickly tap twice, holding down on the second tap until you hear the beep. Once stored, you can select the same station by quickly tapping this Preset button twice.

CD Player

Loading a CD

Open the flip-down door. Insert a disc, label side up, into the slot. The CD player will automatically draw the disc in and play it.

If the red light next to the **Eject** button is blinking, there is already a disc in the CD player. **DO NOT INSERT A DISC IF THE RED LIGHT IS BLINKING.** Press the **Eject** button and the red light will go out after the disc is ejected. When there is no disc in the CD player, “disc?” will appear in the display.

Warning: Adhesive CD labels may loosen, damaging this or any other CD player. A permanent marker can be used to label the disc.

Note: If a CD fails to eject, press and hold the **Eject** button for 3 seconds.

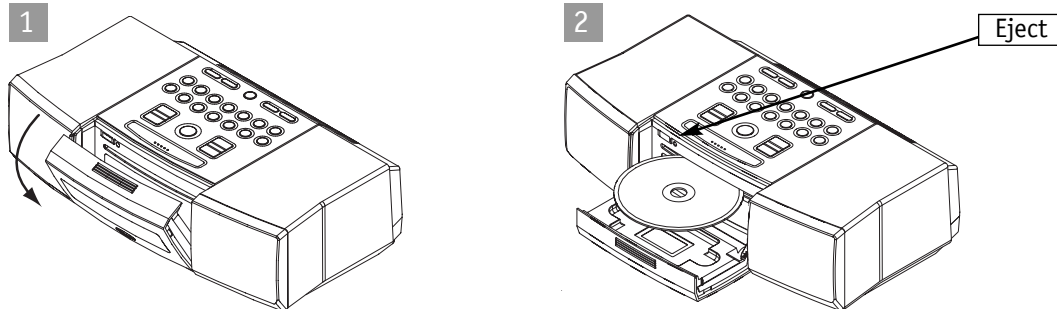

Playing a CD

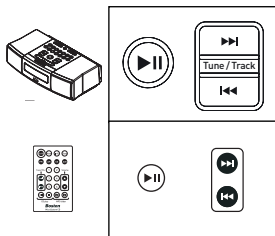

Press the **Play/Pause** button. Press this button again to pause a disc. The arrow next to “CD” in the display will blink. Pressing **Play/Pause** again will resume playback.

To skip to the next or previous track, press the **Tune/Track** arrow buttons. You can advance forward or backward within a track by holding down the **Tune/Track** arrow button.

Repeat and Shuffle

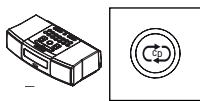

The display will indicate whether “Repeat” or “Shuffle” is activated. Press the **Repeat/Shuffle** button once on the MicroSystem CD to repeat a CD continuously. Press the **Repeat/Shuffle** button a second time to play the songs in a random order. Press the **Repeat/Shuffle** button a third time to activate both **Repeat** and **Shuffle** at the same time. This setting will repeat the shuffle play order continuously. To return to normal playback, press the **Repeat/Shuffle** button until “Repeat” and “Shuffle” disappear from the display window.

CD Player (continued)

MP3/WMA discs

The MicroSystem CD can play CD-R and CD-RW discs encoded with MP3 or WMA music files. “MP3” or “WMA” will appear in the display when these types of files are playing. These discs behave differently from standard CDs. When a disc is inserted, the CD player first must read its directory and number all the tracks. This process may take up to 20 seconds or more if the disc contains many songs. A flashing “CD” will show in the display.

Creating MP3/WMA discs on your computer

If a disc is created with a little planning, it can be made more convenient to navigate. If you group the MP3/WMA song files on your disc in a series of top-level folders with about 10-20 songs (or one album) in each folder, the MicroSystem CD can be conveniently operated like a CD changer from the Remote Control; see “Playing MP3/WMA discs,” below. Otherwise, you can simply place all your song files at the top level of the disc or use any other arrangement of files and folders.

Playing MP3/WMA discs

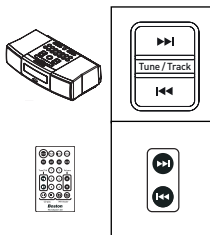

You can navigate MP3/WMA files using the **Tune/Track** arrow buttons, just as with standard CD tracks.

To go to the previous or next song file, press the **Tune/Track** arrow button.

To move forward or backward within a song, hold down the **Tune/Track** arrow button.

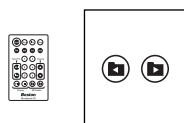

The Remote Control has two additional arrow buttons, marked “MP3 folder.” These jump to the previous or next folder on the disc. This is a fast and easy way to move through many song files, if you have created your disc with the songs grouped in top-level folders as explained above. If so, the **MP3 folder** buttons act like the disc change buttons on a CD changer.

The MicroSystem CD assigns and displays a track number for every song file on the disc, in one continuous series, regardless of any folders.

Alarms

Setting the alarms

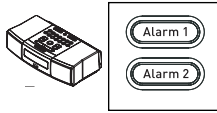

Press the **Alarm 1** (or **Alarm 2**) button repeatedly to choose the desired alarm mode—one press for music, two presses for beeper, three presses for music + beeper. Pressing the **Alarm** button a fourth time will cancel the alarm. The display will indicate if an alarm is set and its mode of operation. In the music + beeper setting, the MicroSystem CD plays for 5 minutes and then switches to the beeper sounds.

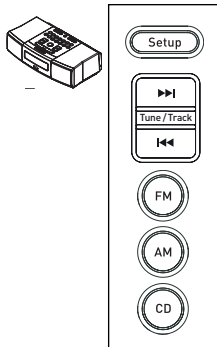

After choosing the alarm mode above, press the **Setup** button (for **Alarm 1** or for **Alarm 2**). While the display is flashing, you can set:

- Wakeup time: use the **Tune/Track** arrow buttons.
- Alarm music source (if music is the alarm mode): Use the **FM**, **AM**, or **CD** button.
- Alarm radio station: If FM or AM is your preferred music source, use the Preset buttons to choose a station. The alarm station must be chosen from the stored presets; see page 7.
- Alarm CD track: If CD is your preferred music source and there is a CD in the player: Press the **CD** button repeatedly to set a wakeup track (because the usual **Tune/Track** buttons are temporarily reserved for the wakeup time setting). Press and hold down the **CD** button to go back to track 1. If the CD is removed before the alarm triggers, the source will be changed to beeper to ensure that an alarm sounds.

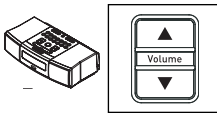

- Alarm volume: Use the **Volume** arrow buttons to set the alarm volume. The alarm volume is then stored, and is independent of the volume changes that you make when playing the MicroSystem CD manually.

Alarms (continued)

Checking the wakeup time



Press the **Setup** button for **Alarm 1** (or **Alarm 2**). The wakeup time and other alarm settings will flash in the display for a few seconds. To cancel the flashing immediately, press the **Setup** button again.

Stopping the alarm when it is sounding

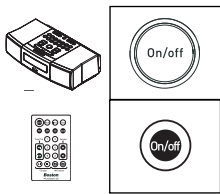

Press the **On/off** button or any other button except the **Snooze/Sleep** button. The alarm will stop, and will trigger again at the same time the next day.

Disabling the alarm (for weekends, etc.)

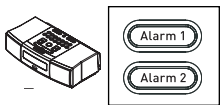

Press the **Alarm 1** (or **Alarm 2**) button repeatedly until the alarm icon disappears in the display. The alarm settings will remain stored, but the alarm will not be active.

Using the Snooze function

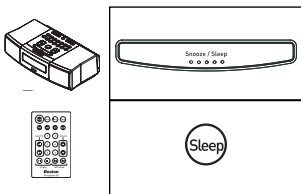

When the alarm sounds, press the **Snooze/Sleep** button on the MicroSystem CD or the **Sleep** button on the Remote Control once to silence the alarm for 10 minutes.

If the **Snooze/Sleep** button or the **Sleep** button is pressed again within 3 seconds of the first push, 5 minutes will be added to snooze time, up to a maximum of 60 minutes. Example: If the button is pushed rapidly three times, the MicroSystem CD will go into snooze mode for 20 minutes (10 + 5 + 5 minutes).

Once the MicroSystem CD is in snooze mode, tapping the **Snooze/Sleep** or **Sleep** button will display the remaining snooze time, counting down. The display will then revert to normal after 5 seconds.

Alarms (continued)

Using the Sleep function

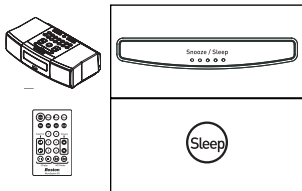

When listening to the MicroSystem CD, this function turns off the MicroSystem CD automatically after a predetermined “sleep” time.

When the MicroSystem CD is playing normally (no alarm is sounding), hold down the **Snooze/Sleep** button on the MicroSystem CD or the **Sleep** button on the Remote Control for 2 seconds. The “**Sleep**” indicator is shown in the display, and the initial sleep time of 60 minutes is shown temporarily.

Each additional press of the **Snooze/Sleep** or **Sleep** button will shorten the sleep time in 10-minute increments to the nearest 10 minutes.

While the MicroSystem CD is in the sleep setting, press the **Snooze/Sleep** or **Sleep** button once. The remaining sleep time will be temporarily shown in the display, then the display will revert to its normal readout (either the current clock time or radio frequency, depending on which has been selected).

More Features

Changing the display information

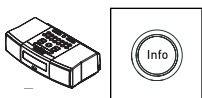

You can tailor the display to show your preferred information, such as whether to show clock time or station frequency while playing the radio; or to show clock time, CD track number, or CD track time when playing a disc. Press the **Info** button repeatedly to pick your preferred display. Each music source can remember its own preferred display setting. To check for information that is not currently displayed, use the **Info** button to show the information, and then use it again to return to your previous preferred display.

More Features (continued)

Using headphones

If you plug headphones into the stereo minijack on the front panel, the speakers will be muted except for the alarms. Be sure to use the jack marked with the headphones symbol, not the nearby Aux 3 jack.

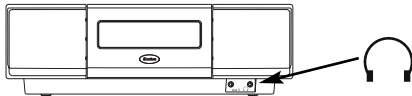

Using other devices (Aux 1, 2, and 3)

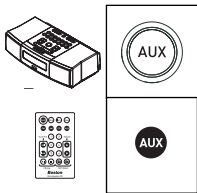

You can play external sources such as a TV, CD changer, or MP3 player through the MicroSystem CD. There are three stereo connections: two via RCA input jacks on the rear panel, and a third via a 1/8" minijack on the front of the MicroSystem CD. The rear-panel aux inputs are for permanent sources such as a TV or a CD changer. The front-panel input (Aux 3) is for portable sources such as an iPod® or Walkman®. The Aux 3 front-panel input is optimized for portable devices and is more sensitive than the rear-panel inputs. When using a portable device with the Aux 3 input, first make sure that the volume level on the portable device is not set to the maximum level. You can adjust the volume control on the portable device to find the best sound without distortion. To choose an Aux source, press the **Aux** button repeatedly until the one you want (Aux 1, 2, or 3) is displayed on the front-panel.

Note: The Aux inputs cannot be chosen as sources for alarm music. See page 10.

Display dimmer sensor control

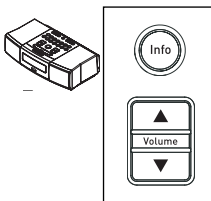

The MicroSystem CD display panel will automatically dim when the room becomes dark. The amount of light it takes to dim the display can be adjusted. Press and hold the **Info** button and then press the **Volume** arrow buttons to adjust the threshold. You will hear a beep on each press of the **Volume** up and down arrows and the display will show a number 1 through 9. “1” indicates the darkest room light setting, and “9” indicates the brightest room light setting.

More Features (continued)

Customizing the MicroSystem CD's output

The MicroSystem CD has a line output which can feed its audio into an external device. Uniquely, you can program this output to tailor it for use as:

- A fixed-level output that ignores the volume setting (useful for recording or for feeding the MicroSystem CD's radio or CD signal to an external receiver that has its own volume control);
- A variable-level output that responds to the MicroSystem CD's volume setting (useful for feeding an external amplifier or powered speaker system that has no volume control); and
- A subwoofer output that feeds bass to an external powered subwoofer and simultaneously reduces the bass fed to the MicroSystem CD's speakers. They will play louder and will match the subwoofer better.

Note: The subwoofer output is not low-passed. Use the subwoofer's crossover, set for best blending (about 110Hz).

Programming the line output

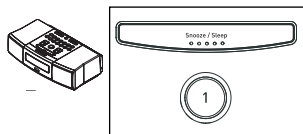

Fixed-level: With the unit powered off, press **Preset 1** and **Snooze/Sleep** together for 5 seconds. "L1" will appear in the display;

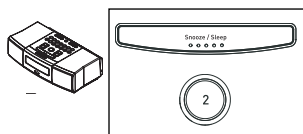

Variable-level: With the unit powered off, press **Preset 2** and **Snooze/Sleep** together for 5 seconds. "L2" will appear in the display;

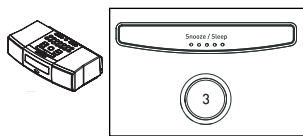

Subwoofer output: With the unit powered off, press **Preset 3** and **Snooze/Sleep** together for 5 seconds. "L3" will appear in the display.

Note: If the subwoofer output is set, a small "S" will show in the display to alert you that bass has been removed from the internal speakers. The subwoofer output sends a summed monaural signal to both left and right RCA jacks.

Using the Bass trim

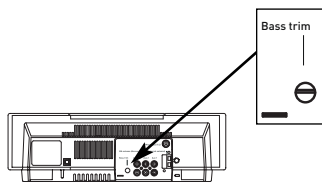

The **Bass trim** knob, located on the back of the unit, is used to adjust the bass level. When the MicroSystem CD is placed near a wall, the bass can become more pronounced. Setting the unit away from a wall can sometimes decrease the bass. Adjust the **Bass trim** to achieve the desired amount of bass output.

Connections

Connecting other devices

There are three stereo connections: two via RCA input jacks on the rear-panel and a third via a minijack on the front of the MicroSystem CD. In addition, a stereo line output via RCA jacks on the rear panel can feed audio into an external device. Example connections are shown in the diagram below.

Note: The subwoofer output configuration sends a summed monaural signal to both the left and right RCA jacks.

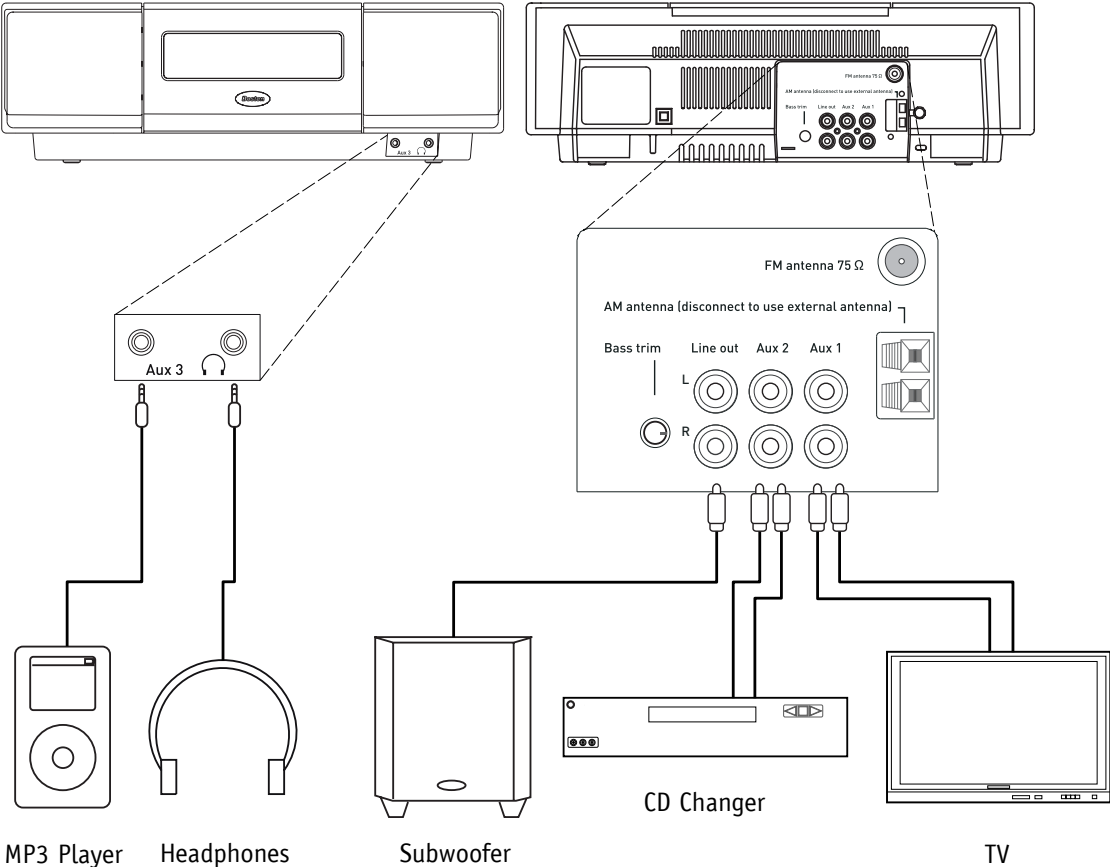

Connections (continued)

Connecting the FM antenna

The FM antenna comes attached. If the antenna is disconnected, follow these steps to connect it:

1. Push the Type F connector plug on the end of the antenna into the receptacle on the MicroSystem CD marked “**FM antenna 75Ω**.”
2. Straighten out the antenna to its full length.
3. Orient the antenna wire for the best reception.

Optional: Connecting to a cable TV signal

You may be able to obtain better reception if your cable company offers an FM radio signal on your TV cable. The MicroSystem CD's FM antenna connector will accept the cable FM feed from most cable TV systems that provide FM programming. To connect your radio to the FM signal available from some cable TV providers, contact your cable TV company for assistance before making any connection.



Be sure that the installation includes a splitter that filters the signal to prevent any remission of the TV spectrum through the MicroSystem CD, so only the FM band, not the cable TV signal, is transmitted to the MicroSystem CD.

Notice for Cable TV System Installer

Please make note of Article 820-40 of the NEC (of USA) that provides guidelines for proper grounding. In particular, this standard specifies that the cable ground shall be connected to the grounding system of the building, as close to the point of cable entry as is practical. **CAUTION:** When making connections to the rear of the MicroSystem CD, it is possible to experience an ESD (Electrostatic Discharge) event. If this happens, simply push the **On/off** button on the front and recheck the preset settings.

Connections (continued)

Optional: Connecting to a different external indoor FM antenna

Note: Not included—available at most stores that sell audio/video parts and accessories.

1. Disconnect the supplied external FM antenna from the back of the MicroSystem CD.
2. Connect the external FM antenna to the 75 Ω Type F connector.

Optional: Connecting to an external indoor AM antenna

Note: Not included—available at most stores that sell audio/video parts and accessories.

1. Disconnect the built-in internal AM antenna wires from the spring terminals on the back of the MicroSystem CD.
2. Connect the wires of the external AM antenna to these terminals.

Optional: Connecting to an outdoor antenna

If you wish to use an outdoor antenna, we suggest that, for safety reasons, you have a professional installer connect it.

Antenna Grounding

Example of antenna grounding,
per the National Electrical Code,
ANSI/NFPA 70.

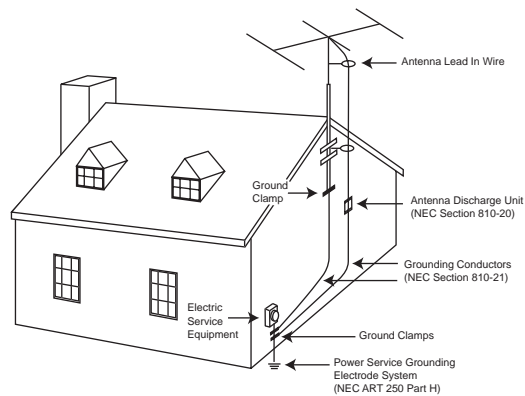

Troubleshooting

The MicroSystem CD does not power up

- Is the system plugged into a working, unswitched electrical outlet?
- Are you using an operating AC wall outlet?

There is no sound coming from the system

- Is the volume turned up? Try increasing the volume.
- Is the system muted? Press the **Mute** button on the Remote Control.
- If playing a CD, make sure that the disc is placed label-side up in the slot and check that the **CD Pause** is turned off.
- If playing the radio, make sure that the antennas are connected, then try tuning to another station.
- Make sure that you are not on an auxiliary input.

Discs do not play when inserted into the slot-loading CD player

- The disc may be dirty. Try cleaning the disc.
- The disc may be defective or the wrong format. Try another disc.
- Eject the disc and try loading it again.

Warning: Adhesive CD labels may loosen, damaging this or any other CD player. A permanent marker can be used to label the disc.

The Remote Control does not work

- Check that the pull tab is removed from the Remote Control.
- The Remote Control battery might need to be replaced. (battery type: CR2025 3-volt)
- Move the Remote Control closer to the unit.

There is too much or not enough bass

- Adjust the bass using the **Bass trim** knob on the rear panel of the MicroSystem CD. See page 14.

Disc error codes in the display

The following error codes will appear on the display if the CD player encounters a problem. In most cases the disc can be ejected and the system will perform as normal. However, if an error code remains displayed, please contact your local dealer or Boston's Technical Support Department for further instructions.

- | | |
|-------------------|--|
| E-4 | CD drive mechanism is jammed or unresponsive. |
| E-5 | CD dirty/scratched or decode error (Examples: Nonsupported file format or bit rate). |
| E-6 | CD drive cannot understand the disc format. |
| E-70,71,72 | CD drive operation error (Examples: upside-down disc, spin jammed, DVD, no supported files, blank disc). |

Specifications

Dimensions

Height 4½" (114mm)
Width 14" (355mm)
Depth 8½" (217mm)

System Weight

9 lbs (4kg)

Batteries

MicroSystem CD Standard 9-volt
Remote Control CR2025 3-volt

Limited Warranty

For one year from the date of purchase, Boston Acoustics will repair for the original owner any defect in materials or workmanship that occurs in normal use of the Boston Acoustics MicroSystem CD, without charge for parts and labor.

Your responsibilities are to use the unit according to the instructions supplied, to provide safe and secure transportation to an authorized Boston Acoustics service representative, and to present proof of purchase in the form of your sales slip when requesting service.

Excluded from this warranty is damage that results from abuse, misuse, accidents, shipping, repairs, or modifications by anyone other than an authorized Boston Acoustics service representative.

This warranty is void if the serial number has been removed or defaced.

This warranty gives you specific legal rights, and you may also have other rights that vary from state to state.

If service seems necessary:

First, contact the retailer from whom you purchased the system. If that is not possible, write to:

Boston Acoustics, Inc.
300 Jubilee Drive
Peabody, MA 01960 USA

We will promptly advise you of what action to take. If it is necessary to return the product to the factory, please ship it prepaid. After it has been repaired, we will return it freight prepaid in the U.S. and Canada.

Index

- AM**
 - Connecting an external indoor AM antenna page 17
 - Control Panel diagram page 5
 - Display diagram page 6
 - Remote Control diagram page 4
 - Setting the alarms page 10
 - Storing AM stations page 7
 - Tuning to an AM station page 7
- Alarms**
 - Checking the wakeup time page 11
 - Control Panel diagram page 5
 - Display diagram page 6
 - Disabling the alarm page 11
 - Remote Control diagram page 4
 - Stopping the alarm when it is sounding page 11
 - Setting the alarms page 10
 - Using the Sleep function page 12
 - Using the Snooze function page 11
- Antenna**
 - Connecting the FM antenna page 16
 - Connecting to a cable TV signal page 16
 - Connecting to a different external indoor FM antenna page 17
 - Connecting to an external indoor AM antenna page 17
 - Connecting to an outdoor antenna page 17
 - Positioning the FM antenna page 4
- Auxiliary Inputs**
 - Control Panel diagram page 5
 - Connecting other devices page 15
 - Display diagram page 6
 - Remote Control diagram page 4
 - Setting the alarms page 10
- Bass Trim**
 - Using the Bass trim page 14
 - Troubleshooting page 18
- Battery**
 - Backup alarm page 3
 - Installing the battery page 3
 - Specifications page 19
 - Troubleshooting page 18
 - Unpacking the MicroSystem CD page 3
- CD**
 - Control Panel diagram page 5
 - Creating MP3/WMA discs page 9
 - Display diagram page 6
 - Loading a CD page 8
 - MP3/WMA discs page 9
 - Playing a CD page 8
 - Playing MP3/WMA discs page 9
 - Remote Control diagram page 4
 - Repeat and Shuffle page 8
 - Setting the alarms page 10
 - Troubleshooting page 18

Index (continued)

Clock	
Control Panel diagram	page 5
Display diagram	page 6
Setting the clock	page 5
Connections	
Cable TV signal	page 16
External indoor AM antenna	page 17
External indoor FM antenna	page 17
FM antenna	page 16
Other Devices	page 15
Outdoor antenna	page 17
Power cord	page 4
Troubleshooting	page 18
Control Panel	
Control Panel diagram	page 5
Display	
Display diagram	page 6
FM	
Control Panel diagram	page 5
Display diagram	page 6
External indoor FM antenna	page 17
FM antenna	page 16
Positioning the FM antenna	page 4
Remote Control diagram	page 4
Storing FM stations	page 7
Setting the alarms	page 10
Tuning to an FM station	page 7
Headphones	
Connecting headphones	page 15
Using headphones	page 13
Line Inputs	
Connecting other devices	page 15
Line Output	
Connecting other devices	page 15
Customizing the line output	page 14
Programming the line output	page 14
MP3/WMA	
Creating MP3/WMA discs	page 9
Connecting an MP3 player	pages 13, 15
MP3/WMA discs	page 9
Playing MP3/WMA discs	page 9
Troubleshooting	page 18
On/off	
Control Panel diagram	page 5
Display diagram	page 6
Remote Control diagram	page 4
Other Devices	
Connecting other devices	page 15
Owner's Manual	
Download a manual from the Web	page 3
Save this owner's manual	page 3

Index (continued)

Presets	
Control Panel diagram	page 5
Display diagram	page 6
Setting the alarms	page 10
Storing FM and AM presets	page 7
Storing a second set of presets	page 7
Setting the alarm	page 10
Radio	
Display diagram	page 6
Setting the alarms	page 10
Storing a second set of presets	page 7
Storing FM and AM presets	page 7
Tuning to an FM or AM station	page 7
Remote Control	
Remote Control diagram	page 4
Troubleshooting	page 18
Repeat	
Control Panel diagram	page 5
Display diagram	page 6
Repeat and Shuffle	page 8
Shuffle	
Control Panel diagram	page 5
Display diagram	page 6
Repeat and Shuffle	page 8
Sleep	
Control Panel diagram	page 5
Display diagram	page 6
Remote Control diagram	page 4
Using the Sleep function	page 12
Snooze	
Control Panel diagram	page 5
Display diagram	page 6
Remote Control diagram	page 4
Using the Snooze function	page 11
Special Features	
Special features	page 2
Specifications	
Batteries	page 19
Dimensions	page 19
System Weight	page 19
Troubleshooting	
Disc error codes	page 18
Troubleshooting	page 18
Unpacking	
Unpacking the MicroSystem CD	page 3
Volume	
Adjusting the volume	page 6
Muting the system	page 6
Setting the alarms	page 10
Warranty	
Limited warranty	page 19

Notes:

Boston
Boston Acoustics

300 Jubilee Drive
Peabody, MA 01960 U.S.A.
978.538.5000
www.bostonacoustics.com

Boston, Boston Acoustics, and the Boston Acoustics logo are registered trademarks of Boston Acoustics, Inc. iPod and the iPod design are registered trademarks of Apple Computers, Inc. Walkman is the registered trademark of Sony Corporation.

© 2004 Boston Acoustics, Inc. All rights reserved. Specifications are subject to change without notice.

042-002203-3